

(19) World Intellectual Property Organization
International Bureau



(43) International Publication Date
24 January 2002 (24.01.2002)

PCT

(10) International Publication Number
WO 02/06822 A1

(51) International Patent Classification?: G01N 33/00,
A61B 5/00

C.; 1 The Cedars, Coombe Road, Wootton-Under-Edge
GL12 7LU (GB). PENAULT, Caroline; 818 Fishponds
Road, Fishponds, Bristol BS16 3TE (GB). CHAMBERS,
Paul; 154 Foxhall Road, Ipswich, Suffolk IP3 8HW (GB).
BLACK, Murdo, M.; High Trees, Shaw Valley Road,
Martlesham, Ipswich IP12 4SH (GB).

(21) International Application Number: PCT/GB01/03163

(22) International Filing Date: 13 July 2001 (13.07.2001)

(25) Filing Language: English

(74) Agents: GEMMELL, Peter, Alan et al.; Dummett Copp,
25 The Square, Martlesham Heath, Ipswich IP5 3SL (GB).

(26) Publication Language: English

(81) Designated States (national): AE, AG, AL, AM, AT, AU,
AZ, BA, BB, BG, BR, BY, BZ, CA, CH, CN, CO, CR, CU,
CZ, DE, DK, DM, DZ, EC, EE, ES, FI, GB, GD, GE, GH,
GM, HR, HU, ID, IL, IN, IS, JP, KE, KG, KP, KR, KZ, LC,
LK, LR, LS, LT, LU, LV, MA, MD, MG, MK, MN, MW,
MX, MZ, NO, NZ, PL, PT, RO, RU, SD, SE, SG, SI, SK,
SL, TJ, TM, TR, TT, TZ, UA, UG, UZ, VN, YU, ZA, ZW.

(30) Priority Data:
0017239.5 14 July 2000 (14.07.2000) GB

(71) Applicant: HYPOGUARD LIMITED [GB/GB]; Dock
Lane, Melton, Woodbridge, Suffolk IP12 1PE (GB).

(84) Designated States (regional): ARIPO patent (GH, GM,
KE, LS, MW, MZ, SD, SL, SZ, TZ, UG, ZW), Eurasian
patent (AM, AZ, BY, KG, KZ, MD, RU, TJ, TM), European
patent (AT, BE, CH, CY, DE, DK, ES, FI, FR, GB, GR, IE,
IT, LU, MC, NL, PT, SE, TR), OAPI patent (BF, BJ, CF,
CG, CI, CM, GA, GN, GW, ML, MR, NE, SN, TD, TG).

[Continued on next page]

(54) Title: METHOD FOR DETECTION OF HELICOBACTER PYLORI AND APPARATUS THEREFOR

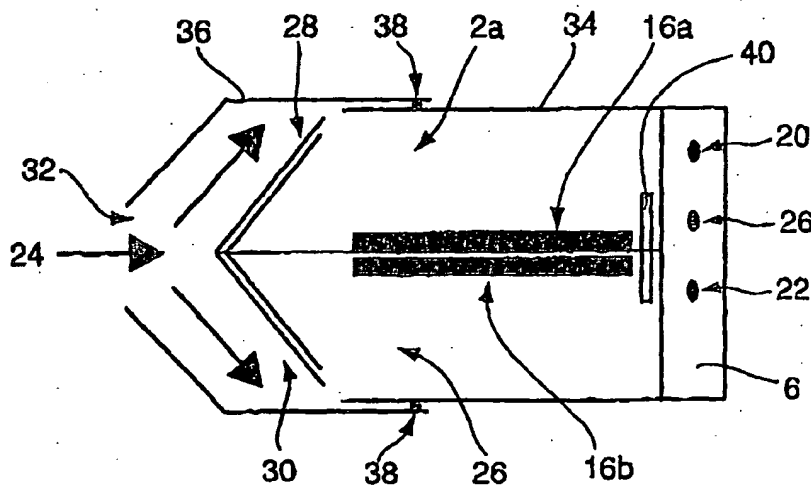

(57) Abstract: A method for detecting Helicobacter pylori in a subject's gastrointestinal tract involves measuring a change in resistance of an electronic or electrochemical sensor, notably a polypyrrole film, on exposure to gas from the subject's lungs and/or stomach. Depending on the magnitude of the change (if any) a positive or negative result is indicated visually by electronics means. Two sensors (16) are used, one of which receives a sample of gas (24) which has passed through an ammonia-absorbing means (30) to provide a corrected baseline value for the ammonia. The invention also provides apparatus suitable for carrying out the method.



WO 02/06822 A1



Published:

- with international search report
- before the expiration of the time limit for amending the claims and to be republished in the event of receipt of amendments

For two-letter codes and other abbreviations, refer to the "Guidance Notes on Codes and Abbreviations" appearing at the beginning of each regular issue of the PCT Gazette.

METHOD FOR DETECTION OF HELICOBACTER PYLORI AND APPARATUS THEREFOR

Field of the Invention

5 The present invention relates to a device and method for detecting *Helicobacter Pylori* in human subjects.

Background of the Invention

10 It has been known for some time that infection by *Helicobacter pylori* (*H pylori*) may increase the risk of a subject suffering from illnesses such as gastritis and duodenitis, and from peptic and duodenal ulcers. Detection of *H pylori* is therefore desirable to determine
15 whether patients have, or have increased risk of having, such illnesses, and to enable appropriate treatment to be given.

H pylori produces ammonia and carbon dioxide by the action
20 of a urease on urea in bodily fluids, and various tests have been proposed to detect *H pylori* by detecting the products of this reaction.

A test which is currently in use involves administering
25 ¹³C-labelled urea to the subject and subsequently testing carbon dioxide in the subject's breath for the presence of ¹³C. However, testing for ¹³C requires a sample to be sent away for laboratory testing, which is slow and relatively expensive.

30 Various methods are known for diagnosing the presence of *H pylori* in human subjects. In US 4,947,861 it was proposed to detect the presence of ammonia in a subject's breath following oral administration of urea. The method
35 comprises collecting a sample of alveolar air at least ten minutes after administration of the urea, passing the air over an alkaline hygroscopic material to remove water

- 2 -

vapour, and passing the dried alveolar air to a sensor which indicates the presence of ammonia. The sensor described is a glass tube filled with a granular material that changes colour as ammonia is passed through it.

5 DE 299 02 593 U1 describes the use of an electronic "nose" for detecting infection by H pylori, and other conditions such as lactose intolerance, enzyme shortages, bacterial or viral infections. The electronic nose produces a fingerprint which is compared with a stored databank to
10 produce a diagnosis. US 5,719,052 describes a method and apparatus for collecting gas from a subject's stomach by stimulating the subject's vomiting reflex.

International Patent Application WO 97/3035 describes
15 various chemical indicators which change colour in the presence of ammonia to provide a visible indicator of ammonia in a subject's breath.

It is desirable to have a detection device and method for
20 detecting H pylori which is non-invasive, speedy, and which can be used by a patient or other person without medical supervision.

Summary of the Invention

25

According to a first aspect of the present invention there is provided a method for detecting the presence of Helicobacter pylori in the gastroenteral tract of a subject, the method comprising the steps of:

- 30 a) obtaining a volume of gas from the lungs and/or stomach of the subject;
- b) dividing the said volume of gas into first and second substantially equal portions;
- 35 c) causing or permitting the first said portion of gas to come into intimate contact with a first electronic or electrochemical ammonia sensor connected to means for

- 3 -

measuring the electrical resistance of the said first sensor;

d) causing or permitting the second said portion of gas to come into intimate contact with ammonia absorbing means and then into intimate contact with a second electronic or electrochemical ammonia sensor connected to means for measuring the electrical resistance of the said second sensor;

e) measuring the resistance of the first and second sensors when in contact with the said portions of gas;

f) comparing the said resistances of the sensors to produce a compared value; and

g) producing a visible output signal to indicate a positive or negative diagnosis of *Helicobacter pylori* infection according to whether or not the compared value exceeds a predetermined threshold value.

The method is non-invasive, and it can be speedy and easy for a patient or other subject to self-administer. It is not necessary to administer urea to the subject prior to carrying out the method.

An antacid (for example magnesium hydroxide) may be administered orally prior to testing. This will promote conversion of ammonium ions in the stomach to gaseous ammonia. If the antacid is a carbonate or bicarbonate (for example sodium bicarbonate), it will also produce carbon dioxide to facilitate eructation.

A pair of similar sensors are provided, each in its own chamber. The gas is distributed substantially equally between the two chambers, but one chamber has an ammonia-absorbing barrier through which gas passes before coming into contact with the sensor. Electronics means compare the difference between or ratio of resistances of the two sensors and express the result as a visible output. The output could be numeric, but is preferably in the form of

- 4 -

a signal corresponding to either a positive or a negative diagnosis. For example, a green light or a red light could be illuminated.

5 To further increase the sensitivity of the device, the gas could be passed through an alkaline desiccant (for example solid sodium hydroxide) in known manner, to remove water vapour (and some carbon dioxide) before the gas enters the chambers.

10

A preferred sensor comprises a film of polypyrrole, which is connected by electrodes to a suitable meter. Methods of making polypyrrole films suitable for use in the invention are described in GB 2 234 515 and EP 0 206 133.

15 The film preferably has a thickness in the range 50 to 250 μm .

According to another aspect of the present invention there is provided a detection device for measuring ammonia content in gas from a subject's lungs and/or stomach, the device comprising:

- 20 a) a first chamber and a second chamber, each of which has an entrance opening for receiving the said gas, and each of which houses an electronic or electrochemical ammonia sensor connected to means for measuring the electrical resistance of the sensor;
- 25 b) the entrance openings of the chambers being connected to an inlet, the arrangement being such that incoming gas from the inlet will be divided into two substantially equal portions, each of which will pass through a corresponding entrance opening;
- 30 c) means for comparing the resistance of both sensors to produce a compared value;
- d) means for producing a visible output signal according to whether the compared value exceeds a predetermined threshold value; and
- 35 e) wherein the second chamber is provided with means for

- 5 -

absorbing ammonia, located between the entrance opening thereto and the sensor therein whereby at least some gas which enters the second chamber through the entrance opening will pass through the ammonia-absorbing means.

5

Although the term "ammonia-absorbing means" is used herein for convenience, it will be understood that this term includes any means which remove ammonia from the gas. Thus, the term includes ammonia adsorbents and materials which chemically combine with ammonia.

10

A preferred ammonia sensor comprises a film of polypyrrole, connected by electrodes to a suitable meter.

15 In a preferred embodiment, each chamber is provided with an exit vent to facilitate the passage of gas therethrough.

To reduce the volume of "dead space" in the chambers, they 20 may optionally be constructed to be expandable, for example by having elastic walls, by being of telescopic construction, or by having a movable plunger, like a syringe. By reducing dead space, and therefore dilution of the gas portions, the sensitivity of the method can be 25 increased.

- 6 -

Brief Description of the Drawings

The invention will now be further described, by way of example, with reference to the following drawings in
5 which:

10 Figure 1 is a schematic representation of one chamber of an ammonia detection device in accordance with an aspect of the present invention;

Figure 2 is a graph showing change in resistance of the device of Figure 1, for different subjects;

15 Figure 3 is a graph of response against time for the device of Figure 1;

Figure 4 is a schematic representation of an ammonia detection device in accordance with the present invention; and

20 Figure 5 shows changes in electrical resistance measurement results for subjects under a defined test protocol.

25 Detailed Description

The experimental device for detecting gaseous ammonia shown in Figure 1 comprises a chamber 2 in which is housed an ammonia sensor 4. The sensor 4 comprises a polypyrrole
30 film 16, about 50 μm thick, which changes its electrical resistance in the presence of ammonia. The film 16 is carried on a pcb-type conductive board, for example Veroboard™, which has been etched to remove conductive
35 material completely across the middle of the sensor 4, so that the two ends 18 of the board are not in electrical contact with each other. An insulating film of PEEK is

- 7 -

disposed between the film 16 and the conductive board. The film 16 is in electrical contact at opposed edges with each conductive end portion 18. The end portions 18 are each connected by wires 14 to a meter 6 which measures electrical resistance across the film 16. In practice, a corresponding chamber will be provided, illustrated in Figure 4, which is of similar construction but which includes an ammonia-absorbing material. This provides a corrected baseline value.

10

The inside of the chamber 2 is maintained at 100% humidity and sealed by clingfilm, in this example Nescofilm™. When the device is used in the method of the invention, a sample of gas 24 from a subject's lungs and/or stomach is collected in a syringe 8 and introduced into the chamber 2 via a needle 10. The meter 6 records the electrical resistance of the polypyrrole film 16 before the gas 24 is introduced into the chamber 2, and again after the gas has been introduced. The meter 6 then compares the resistances to produce a compared value and lights up an LED 20 or 22 according to whether the compared value is above or below a predetermined threshold. The meter 6 may measure the difference in resistance, or a ratio of resistances. The threshold value is calibrated to be just below the value produced by samples from test subjects known to be infected with H pylori. If the LED 22 lights up, showing a value which corresponds to infection, the subject knows to seek appropriate treatment or confirmatory alternative testing.

30

Figure 2 shows test results for two groups of control subjects, one group known to be H pylori negative and the other H pylori positive. In each case, a 10 ml sample of gas 24 was collected and introduced into a chamber of about 10 to 15 ml volume. The film 16 was 10 mm square. The two sets of results on the left are for a breath test

35

- 8 -

only, and the two sets of results on the right (the 'belch test') are for gas collected from subjects' stomachs, following ingestion of sodium bicarbonate in water. In each case, there is a clear threshold between the measured
5 resistance for the negative and positive groups.

The same test conditions were used to check the response of sensors over time, but using a known concentration (100 ppm) of ammonia in air. The sensors were maintained
10 at 100% humidity. The results are shown in Figure 3, with percentage change in resistance being plotted against the time (days) in which the sensor 4 was maintained in the chamber 2 prior to the measurement being taken. For all times up to 60 days, the percentage change was at least
15 15%.

The device shown in Figure 4 comprises a first chamber 2a housing a first sensor 16a, and a second chamber 2b housing a second sensor 16b. The chambers 2a and 2b
20 formed from an inner tubular member 34 and an outer tubular member 36 with a gas-tight seal 38 therebetween. Because the tubular members 34, 36 are telescopically nested together, the chambers 2 can expand as gas is introduced into them, thereby reducing dead space. The
25 chambers 2 and sensors 16 are of identical shape and construction. The first chamber has an entrance opening which is substantially occupied by a first porous frit 28, and the second chamber has an entrance opening which is substantially occupied by a second porous frit 30. The
30 frits 28, 30 are arranged and composed such that each provides substantially the same resistance to the passage of gas 24 which is provided through a common entrance opening 32, for example by a subject breathing through that
35 entrance. Each chamber may optionally be provided with a vent opening (40) to facilitate the flow of gas through the chambers. The second frit 30 is provided with means

- 9 -

for absorbing ammonia, for example sodium dihydrogen phosphate or copper sulphate crystals, so that at least some of the ammonia (and preferably substantially all of the ammonia) which may be present in gas 24 blown into the second chamber 2b is absorbed in the second frit 30 and does not reach the second sensor 16b. The first frit 28 does not significantly absorb ammonia, so that ammonia which is present in gas 24 blown into the first chamber 2a reaches the first sensor 2a.

10

Both sensors 16 are connected by wires (not shown) to an integral meter 6. The meter 6 is optionally provided with means (not shown) for detecting gas flow in the chambers 2. A first LED 26 on the meter 6 lights up when it detects the passage of gas 24. The meter 6 measures the resistance of both sensors and produces a compared value which is the ratio of the resistances. The meter 6 displays a visible output accordingly, by illuminating (green) LED 20 corresponding to a negative test for *H. pylori*, or (red) LED 22 corresponding to a positive test.

Based on data from *in vitro* studies, five healthy *H. pylori*-negative volunteers (determined by the ^{13}C breath test) were studied. In this work, the polypyrrole film was fabricated by dip coating a colloidal suspension of poly(pyrrole), after chemical oxidation of the pyrrole monomer, on an acrylic sheet using known methods (Ratcliffe NR. Poly(pyrrole)-based sensor for hydrazine and ammonia. *Analytica Chimica Acta* 1990; 239: 257-262; Ratcliffe NR. The simple preparation of a conducting and transparent poly(pyrrole) film. *Synthetic Metals* 1990; 38: 87-92).

The resultant film, approximately 50nm thick, has a surface topography (revealed by transmission electron and atomic force microscopy) composed of spheres in intimate contact with each other. The volunteers were studied twice

- 10 -

in random order on two separate days after an overnight fast; once after ingestion of an empty gelatin capsule and once after ingestion of a capsule containing 10 mg of NH_4Cl . Three additional volunteers were studied only after
5 ingestion of NH_4Cl . Ten minutes after the capsule (a time sufficient for capsule degradation according to pharmacopoeia standards and our own *in vitro* observations), each subject swallowed a mixture of 15 ml of Milk of Magnesia® (BCM Ltd, Nottingham: containing 415
10 mg of $\text{Mg}(\text{OH})_2$ per 5 ml) and 50 ml of water and, a further ten minutes later, drank 100 ml of sparkling water to 'drive off' any NH_3 . Mouth air samples (10 ml) were collected into a syringe at baseline (before the capsule); immediately prior to the Milk of Magnesia®/water mixture;
15 and, finally, ten minutes after the 100 ml of sparkling water. These samples were individually expelled into a vial containing the NH_3 sensor linked to a multimeter (measuring resistance) as described above. Pilot studies suggested, in contrast to *in vitro* data, that cold (4°C)
20 sparkling water was superior to still water, so the former was used in all *in vivo* studies.

Five patients (three males and two females) who tested positive for *H. pylori* with at least one clinically-
25 validated test (e.g., ^{13}C breath test, serology) underwent the same procedure but without taking NH_4Cl .

In vivo studies: *H. pylori*-negative subjects
Figure 5 summarises the changes in sensor chemoresistivity
30 of mouth air in *H. pylori*-negative subjects who had ingested 10 mg NH_4Cl or an empty gelatin capsule. Figure 5 shows changes in electrical resistance for subjects exposed to mouth air from *H. pylori*-negative subjects ("negative" controls), *H. pylori*-negative subjects after
35 ingestion of 10 mg ammonia chloride ("positive controls")

- 11 -

and *H. pylori*-positive patients. On average, NH_3 levels detected in mouth air after ingestion of the NH_4Cl -containing capsule, but prior to administration of the Milk of Magnesia/water mixture, were almost twice those seen after ingestion of the placebo. Furthermore, these data were obtained without the subjects necessarily belching.

In vivo studies: *H. pylori*-positive patients
Five *H. pylori*-positive patients underwent the test protocol without taking the NH_4Cl -containing capsule. The results are also shown in Figure 5. Pre-protocol NH_3 levels in the patients' mouths were higher than the baseline levels measured in the *H. pylori*-negative subjects who ingested NH_4Cl ("positive controls"). Furthermore, even higher levels were recorded in the four patients in whom the test protocol produced a belch.

None of the healthy volunteers or the *H. pylori*-positive patients experienced any adverse effects from the study.

The device and method of the present invention can detect sub-ppm concentrations of NH_3 in 'endogenous' mouth air, and can provide a point-of-care diagnostic test for *Helicobacter pylori* without the need for patients to ingest urea, and with the results being immediately available to the attending physician. Furthermore, the conditions necessary for the bacteria-associated NH_4^+ to be converted to NH_3 and liberated through the oral cavity can be achieved through the use of an established antacid and cold, sparkling water with no adverse reactions amongst the small number of healthy subjects and *H. pylori*-positive patients so far tested.

Studies in the healthy volunteers clearly showed that NH_3 levels in mouth air after ingestion of 10 mg NH_4Cl were

- 12 -

generally higher than in the same subjects tested without ingestion of NH_4Cl (Figure 5). This difference was evident irrespective of whether or not the subjects belched. Removing the requirement to belch is seen as a significant advantage for a diagnostic test as, in a study with a larger number of normal subjects, only a proportion were induced to belch reliably under our current protocol.

Given the small number of subjects tested, there is some overlap in the data between those who ingested NH_4Cl and those given the placebo. However, the data in Figure 5 show markedly higher levels of mouth NH_3 in the overnight fasted *H. pylori*-positive patients than in either group of controls. Thus, the patients had higher baseline (without the need to belch) NH_3 levels than the healthy subjects even after the latter had ingested 10 mg NH_4Cl .

Furthermore, four of the five patients did belch and, in each case, this was associated with even higher mouth NH_3 levels. All these *in vivo* data were acquired without any subject or patient being required to ingest urea. The data also suggest that intra-gastric levels of NH_3 in patients with *H. pylori* infection are considerably higher than those attained by the ingestion of 10 mg of NH_4Cl .

The invention provides a rapid, point-of-care diagnostic test for *H. pylori* based on the chemiresistive detection of NH_3 in mouth air. The proposed test does not require patients to ingest urea, and appears to be possible on 'endogenous' mouth air without the need for the patient to belch or even to ingest the antacid/water mixture. Additionally, the test method uses neither stable nor radioactive isotopes thus obviating the need to send samples to a central laboratory for analysis, and overcoming difficulties associated with radioisotopes.

35

Claims

1. A method for detecting the presence of *Helicobacter pylori* in the gastroenteral tract of a subject, the method comprising the steps of:
- a) obtaining a volume of gas from the lungs and/or stomach of the subject;
 - b) dividing the said volume of gas into first and second substantially equal portions;
 - 10 c) causing or permitting the first said portion of gas to come into intimate contact with a first electronic or electrochemical ammonia sensor connected to means for measuring the electrical resistance of the said first sensor;
 - 15 d) causing or permitting the second said portion of gas to come into intimate contact with ammonia absorbing means and then into intimate contact with a second electronic or electrochemical ammonia sensor connected to means for measuring the electrical resistance of the said second sensor;
 - 20 e) measuring the resistance of the first and second sensors when in contact with the said portions of gas;
 - f) comparing the said resistances of the sensors to produce a compared value; and
 - 25 g) producing a visible output signal to indicate a positive or negative diagnosis of *Helicobacter pylori* infection according to whether or not the compared value exceeds a predetermined threshold value.
- 30 2. A method as claimed in claim 1, wherein substantially all of the said second portion of gas passes through the said ammonia absorbing means before coming into contact with the said second ammonia sensor so that substantially all of the ammonia which may be present in the said second portion of gas is absorbed by the ammonia absorbing means.
- 35 3. A method as claimed in claim 1 or claim 2, wherein

- 14 -

each of the said ammonia sensors is housed in a chamber and entrance of a portion of gas into the said chamber causes the chamber to expand.

- 5 4. A method as claimed in any one of the preceding claims, wherein an antacid is administered orally to the subject prior to obtaining the gas from the subject's lungs and/or stomach.
- 10 5. A method as claimed in any one of the preceding claims, wherein sparkling water is administered orally to the subject prior to obtaining the gas from the subject's lungs and/or stomach.
- 15 6. A detection device for measuring ammonia content in gas from a subject's lungs and/or stomach, the device comprising:
- a) a first chamber and a second chamber, each of which has an entrance opening for receiving the said gas, and
20 each of which houses an electronic or electrochemical ammonia sensor connected to means for measuring the electrical resistance of the sensor;
- b) the entrance openings of the chambers being connected to an inlet, the arrangement being such that incoming gas
25 from the inlet will be divided into two substantially equal portions, each of which will pass through a corresponding entrance opening;
- c) means for comparing the resistance of both sensors to produce a compared value;
- 30 d) means for producing a visible output signal according to whether the compared value exceeds a predetermined threshold value; and
- e) wherein the second chamber is provided with means for absorbing ammonia, located between the entrance opening
35 thereto and the sensor therein whereby at least some gas which enters the second chamber through the entrance opening will pass through the ammonia-absorbing means.

- 15 -

7. A device as claimed in claim 6, wherein each chamber is provided with a frit or baffle, each of which provides a substantially equal resistance to the passage of gas.
- 5
8. A device as claimed in claim 7, wherein the said ammonia-absorbing means is provided on the frit or baffle associated with the second chamber.
- 10
9. A device as claimed in any one of claims 6 to 8, wherein each chamber is provided with an exit vent to facilitate the passage of gas therethrough.
- 15
10. A device as claimed in any one of claims 6 to 9, wherein the ammonia-absorbing means comprises sodium dihydrogen phosphate or copper sulphate.
- 20
11. A device as claimed in any one of claims 6 to 10, further including detection means for detecting the passage of breath one or both chambers, and display means responsive to said detection means.
- 25
12. A device as claimed in any one of claims 6 to 11, which is arranged and constructed so that substantially all of the gas which comes into contact with the second sensor via the entrance opening of the second chamber will pass through the ammonia-absorbing means.
- 30
13. A device as claimed in any one of claims 6 to 12, wherein each chamber is expandable.

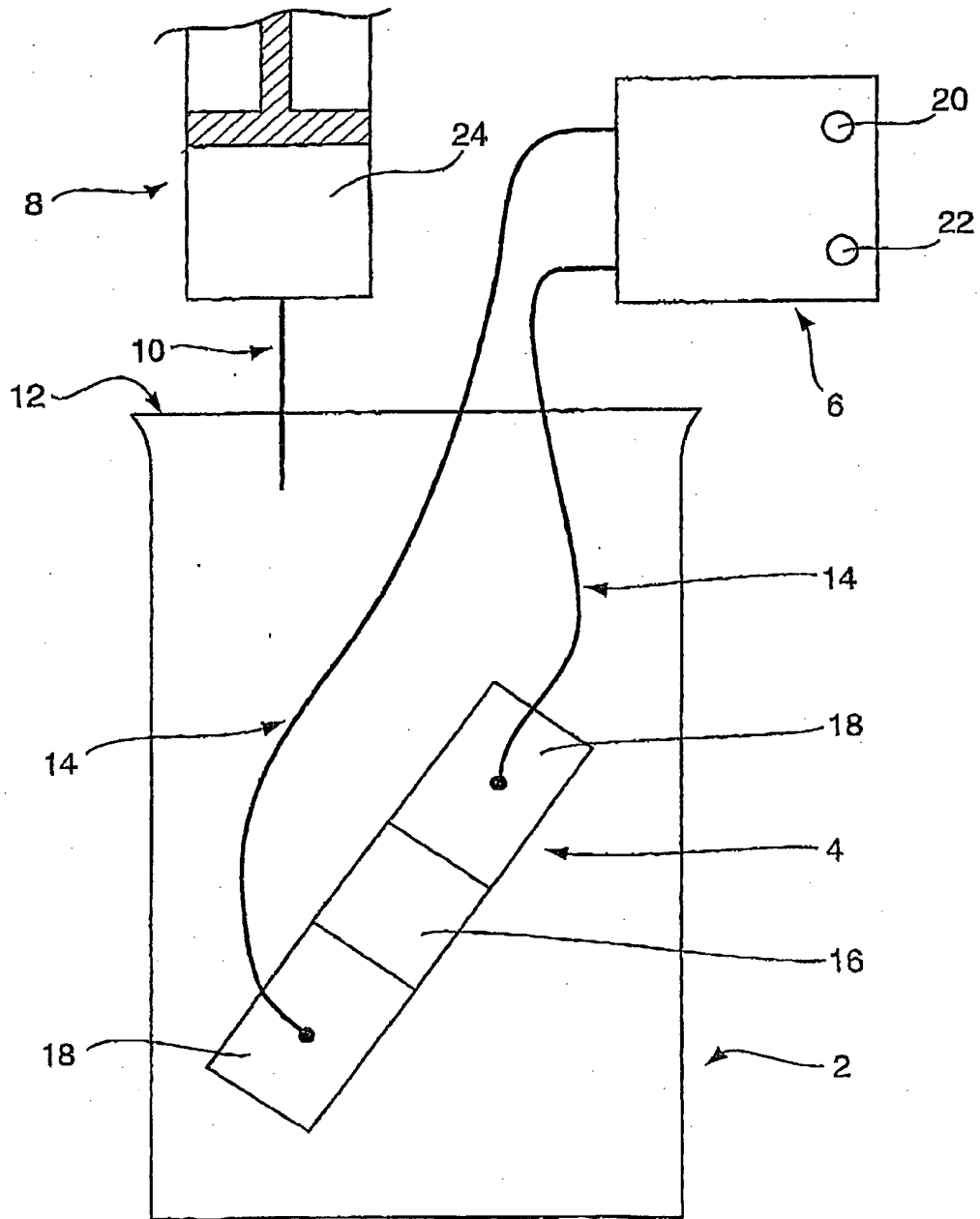

Fig. 1

2/5

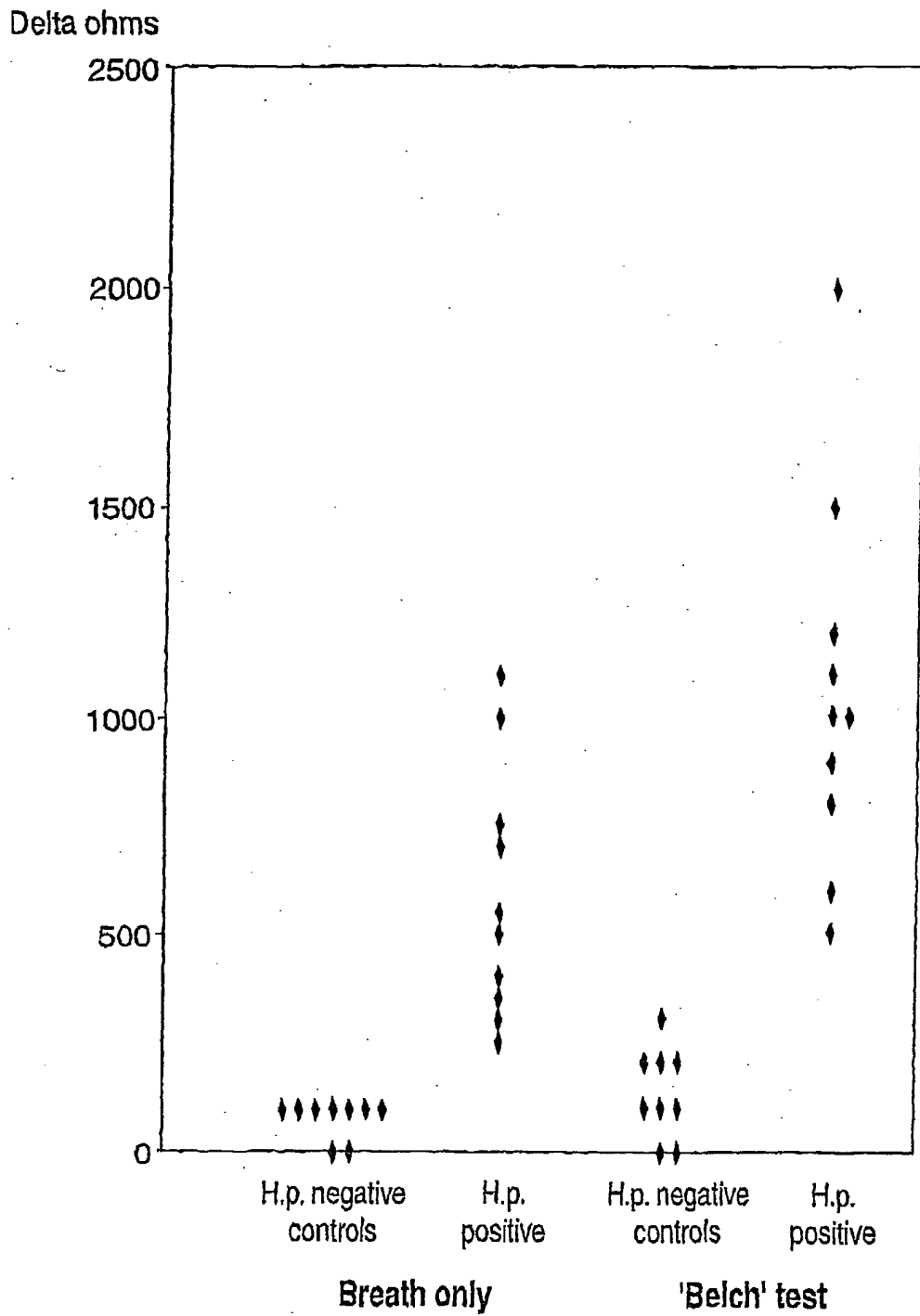

Fig. 2

3/5

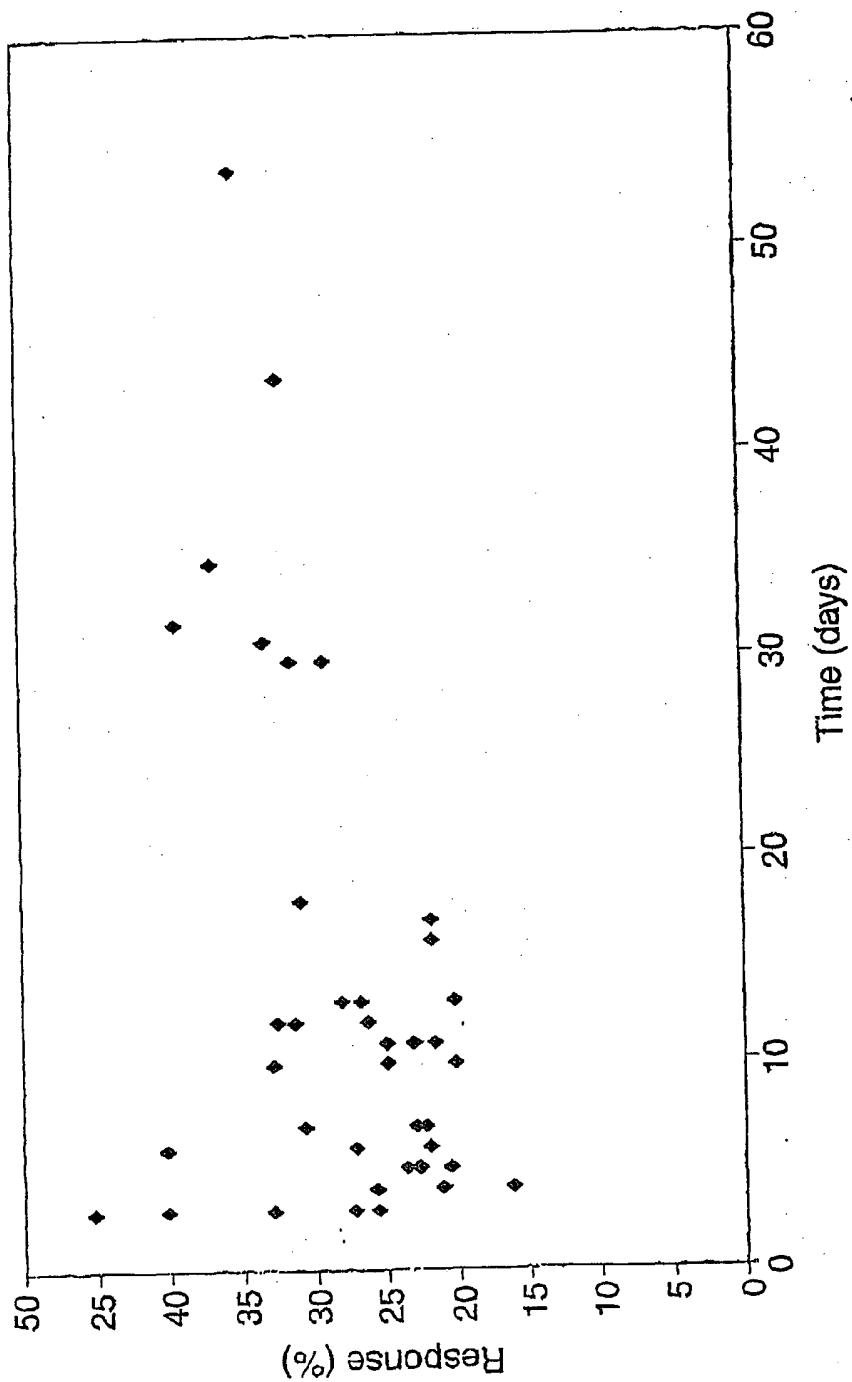

Fig. 3

4/5

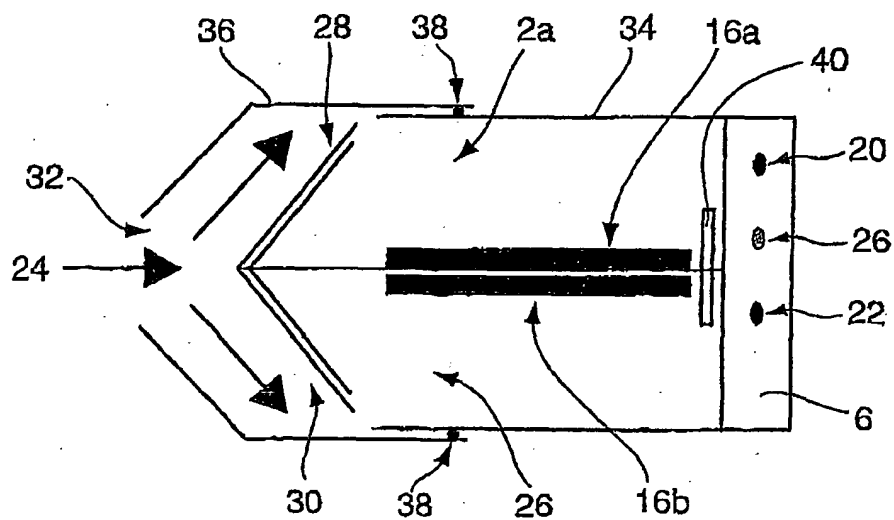

Fig. 4

5/5

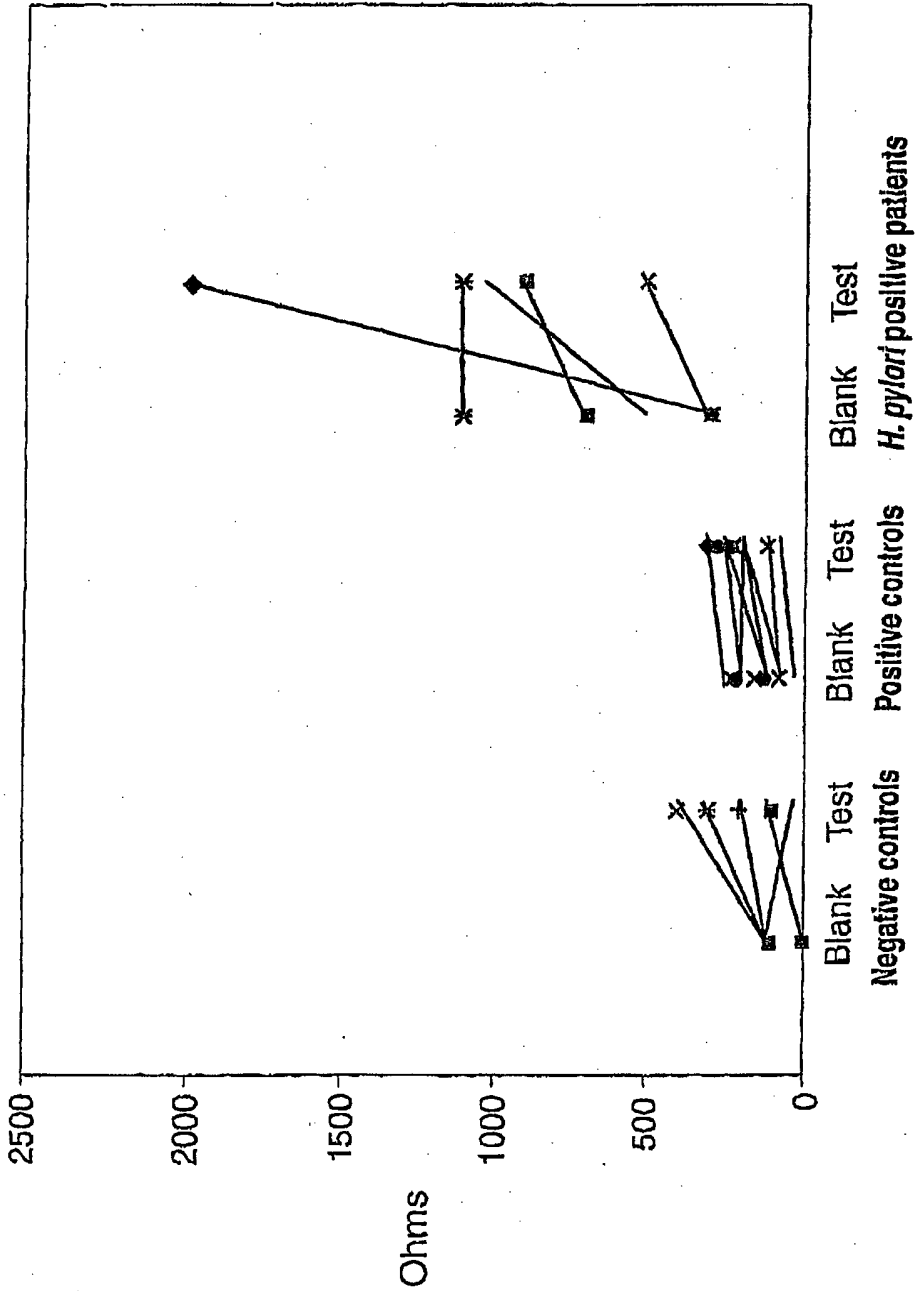

Fig. 5

INTERNATIONAL SEARCH REPORT

International App

PCT/GB 01/03163

<p>A. CLASSIFICATION OF SUBJECT MATTER IPC 7 G01N33/00 A61B5/00</p>		
<p>According to International Patent Classification (IPC) or to both national classification and IPO</p>		
<p>B. FIELDS SEARCHED</p>		
<p>Minimum documentation searched (classification system followed by classification symbols) IPC 7 G01N A61B G06F</p>		
<p>Documentation searched other than minimum documentation to the extent that such documents are included in the fields searched</p>		
<p>Electronic data base consulted during the international search (name of data base and, where practical, search terms used) EPO-Internal</p>		
<p>C. DOCUMENTS CONSIDERED TO BE RELEVANT</p>		
Category *	Citation of document, with indication, where appropriate, of the relevant passages	Relevant to claim No.
A	US 5 057 436 A (BALL DEAN M) 15 October 1991 (1991-10-15) the whole document	6-9, 12
<p><input type="checkbox"/> Further documents are listed in the continuation of box C. <input checked="" type="checkbox"/> Patent family members are listed in annex.</p>		
<p>* Special categories of cited documents:</p> <p>"A" document defining the general state of the art which is not considered to be of particular relevance</p> <p>"E" earlier document but published on or after the international filing date</p> <p>"L" document which may throw doubts on priority claim(s) or which is cited to establish the publication date of another citation or other special reason (see specified)</p> <p>"O" document referring to an oral disclosure, use, exhibition or other means</p> <p>"P" document published prior to the international filing date but later than the priority date claimed</p> <p>"T" later document published after the international filing date or priority date and not in conflict with the application but cited to understand the principle or theory underlying the invention</p> <p>"X" document of particular relevance; the claimed invention cannot be considered novel or cannot be considered to involve an inventive step when the document is taken alone</p> <p>"Y" document of particular relevance; the claimed invention cannot be considered to involve an inventive step when the document is combined with one or more other such documents, such combination being obvious to a person skilled in the art.</p> <p>"Z" document member of the same patent family</p>		
<p>Date of the actual completion of the international search 18 October 2001</p>		<p>Date of mailing of the international search report 07/11/2001</p>
<p>Name and mailing address of the ISA European Patent Office, P.B. 5818 Patentlaan 2 NL - 2280 HV Rijswijk Tel. (+31-70) 340-2040, Tx. 31 851 epo nl, Fax: (+31-70) 340-3016</p>		<p>Authorized officer Bichlmayer, K-P</p>

INTERNATIONAL SEARCH REPORT

Information:
PCT/GB 01/03103

Box I Observations where certain claims were found unsearchable (Continuation of Item 1 of first sheet)

This International Search Report has not been established in respect of certain claims under Article 17(2)(a) for the following reasons:

1. Claims Nos.: 1-5
because they relate to subject matter not required to be searched by this Authority, namely:
Rule 39.1(iv) PCT - Diagnostic method practised on the human or animal body

2. Claims Nos.:
because they relate to parts of the International Application that do not comply with the prescribed requirements to such an extent that no meaningful International Search can be carried out, specifically:

3. Claims Nos.:
because they are dependent claims and are not drafted in accordance with the second and third sentences of Rule 6.4(a).

Box II Observations where unity of invention is lacking (Continuation of Item 2 of first sheet)

This International Searching Authority found multiple inventions in this International application, as follows:

1. As all required additional search fees were timely paid by the applicant, this International Search Report covers all searchable claims.

2. As all searchable claims could be searched without effort justifying an additional fee, this Authority did not invite payment of any additional fee.

3. As only some of the required additional search fees were timely paid by the applicant, this International Search Report covers only those claims for which fees were paid, specifically claims Nos.:

4. No required additional search fees were timely paid by the applicant. Consequently, this International Search Report is restricted to the invention first mentioned in the claims; it is covered by claims Nos.:

Remark on Protest

- The additional search fees were accompanied by the applicant's protest.
- No protest accompanied the payment of additional search fees.

INTERNATIONAL SEARCH REPORT

Information on patent families

International Appl

PCT/GB 01/03163

Patent document cited in search report	Publication date	Patent family member(s)	Publication date
US 5057436	A	15-10-1991	NONE

THIS PAGE BLANK (USPTO)